

CP33 Order Form

User Name:		Order No.:	
Delivery Address:			
Order Quantity:		Expected Delivery Date:	
User Information:	Age:	Height: cm	Weight: kg



5. Leg Length: _____cm

4. Hip to hollow of knee length: _____cm

10. Shoulder width: _____cm

11. Upper Arm Length: _____cm



3. Hip width: _____cm

6. Bottom to bladebone length: _____cm

7. Bottom to shoulder length: _____cm

8. Bottom to head length: _____cm

9. Chest width: _____cm

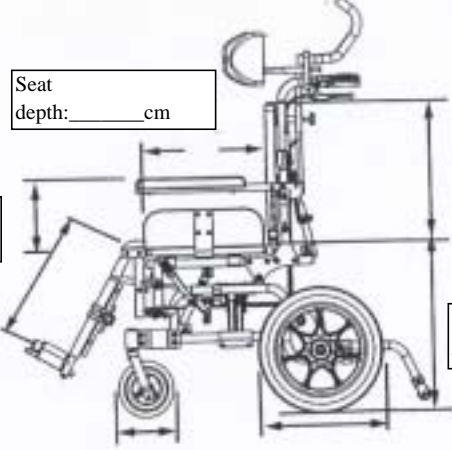

Seat depth: _____cm

Armrest height: _____cm

Calf length: _____cm

Seat height: _____cm

Shoulder height: _____cm

Castor: 6" Rear Wheel: 14"

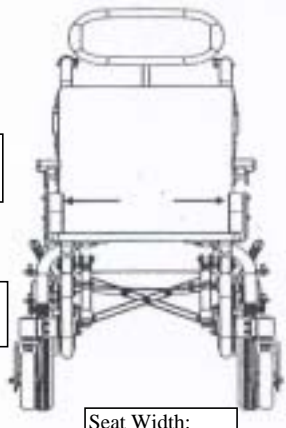

Seat Width: _____cm

Options for CP Chair		
Seat & back upholstery	Double back upholstery	Multi-functional headrest
Foam headrest	Safety belt & H safety belt	Trunk Support
Thigh separator	Thigh loops	Arm loops
Thenar loops	Heel loops	Food tray

Remark